

BS – 250

BAND SAW MACHINE



- **2 CUTTING SPEED LEVELS**
- **BEVEL CUTTING ANGLES AT 45° - 60° - 90°**
- **FLEXIBLE BAND SAW BLADE FOR VARIOUS MATERIALS AND THICKNESSES**



MODEL BS - 250

Main motor	400V, 50 Hz, 0,9/1,4kW
Hydraulic pump motor	400V, 50 Hz, 0,05 kW
Cutting speed (2 Levels)	40/80 (m/min)
Blade size (WxTxL)	2710 x 27 x 0.9mm
Cutting angles	45° - 90°
Drive wheel size	300mm
Table height	910 mm
Oil used in hydraulic systems	PARAMOL HM 46
Cooling box	15 litre
Machine weight	320 kg
Load mass	1000 kg



FEATURES

- High precision positioning to within +/- 0.2mm/250
- Easily turn bevel cutting angles at 90°, 60° và 45°
- The tensioning of blade is driven by hydraulic cylinder, which keeps the blade to be steady, constant during cutting process
- Saw blade is designed to move together with turning table to avoid cutting into jig clamps
- Emergency stop to avert harms or reduce existing hazards to users
- Large-size drive wheel with precise guidance extends band saw life and its accuracy
- Coolant system improves productivity and reducing flying metal chip volume
- A design of solid basement effectively eliminates vibrations in cutting process

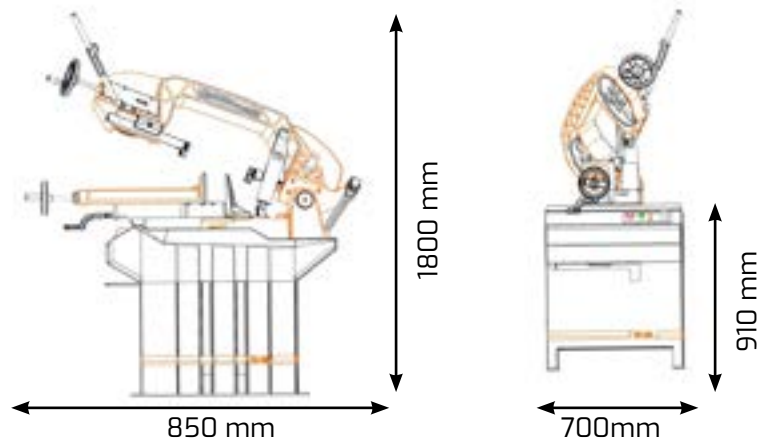
DIMENSIONS



CUTTING CAPACITY

Workpiece/ Cutting angles	90°	45°	60°
	250mm	180mm	110mm
	245mm	180mm	115mm
	290x180mm	190x90mm	110x120mm

BS – 250

BAND SAW MACHINE



- **2 CUTTING SPEED LEVELS**
- **BEVEL CUTTING ANGLES AT 45° - 60° - 90°**
- **FLEXIBLE BAND SAW BLADE FOR VARIOUS MATERIALS AND THICKNESSES**

Circular band saw machine BS 250 is able to cut various different materials, especially for industrial metal cutting.



Materials



Solid steel



Shape steel

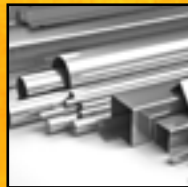

Hollow section



Spring steel



Copper



Aluminum



Plastic

Appropriate to cut various materials with hardness up to 45÷50 HRC

HANOI MECHANICAL COMPANY LIMITED

Head office: 76 Nguyen Trai, Thuong Dinh, Thanh Xuan, Hanoi, Vietnam

Factories: Thuan Thanh 3 Industrial Park, Thanh Khuong, Thuan Thanh, Bac Ninh, Vietnam



Tel: (+84) 024 35587953
(+84) 024 35587952



Email: sales@hameco.com.vn
ktdd@hameco.com.vn



Website: bandsaws.vn
hameco.com.vn